

SNR-052 Temperature Range
-50° - 125° F
SNR-053 Temperature Range
0° - 300° F

Front View

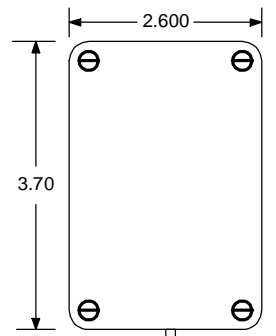

Side View

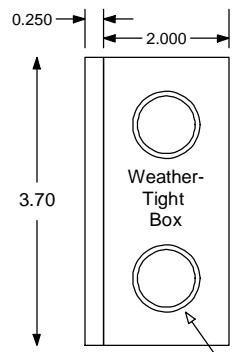

Inside Cover Wiring Detail

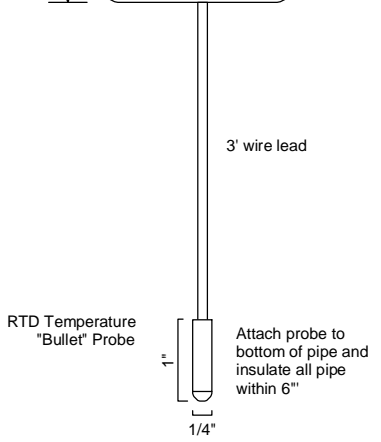
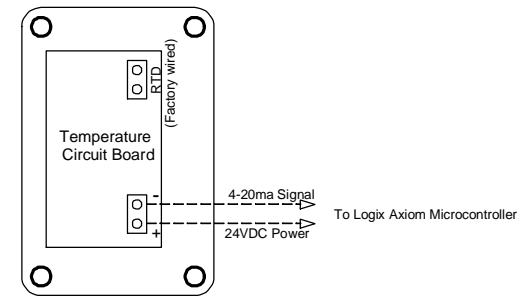

1/2" Conduit Knockout (5 places)

Insulated Pipe Installation Detail

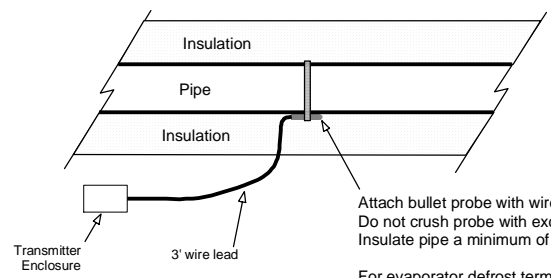

Attach bullet probe with wire tie or hose clamp. Do not crush probe with excessive force. Insulate pipe a minimum of 6" in each direction.

For evaporator defrost termination applications, the bullet probe must be located between the coil outlet and the defrost regulator.

For superheat applications, the bullet probe should be mounted on the pipe at 4 or 8 o'clock in orientation.

NOTES:

- 1) Requires 2 conductor #24 AWG shielded cable Belden 9501 or equal, maximum length of 2000'. Ground shield at control panel end only. Insulate shield at sensor end.
- 2) Sensor transmitter enclosure must be mounted external of pipe insulation.
- 3) Warning: Sensor must be protected from ingress of moisture. The conduit entering the sensor must be sealed internally with foam or putty to completely prevent air movement. Additionally, drill a weep hole at lowest installed point of the enclosure if it exposed to continuous moisture. Moisture damage is not cover by warranty.



© Copyright 2019 Logix® All Rights Reserved.

CONFIDENTIAL: The information herein is confidential and may NOT be reproduced or divulged without the written permission of The Controls Group, Inc. LOGIX is a registered trademark of The Controls Group, Inc.

Title Remote Probe Temperature Sensor Wiring & Installation Detail			
Logix P/N SNR-052 and SNR-053			
Date 07/21/2008	Rev 02	Drawn by MAG	
Drawing Filename SNR-052-053_TempBulletProbe			