

Logix Part Number

SNR-011

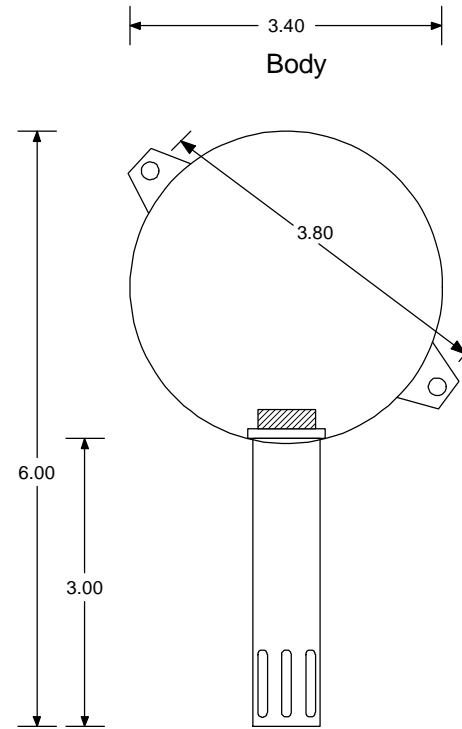
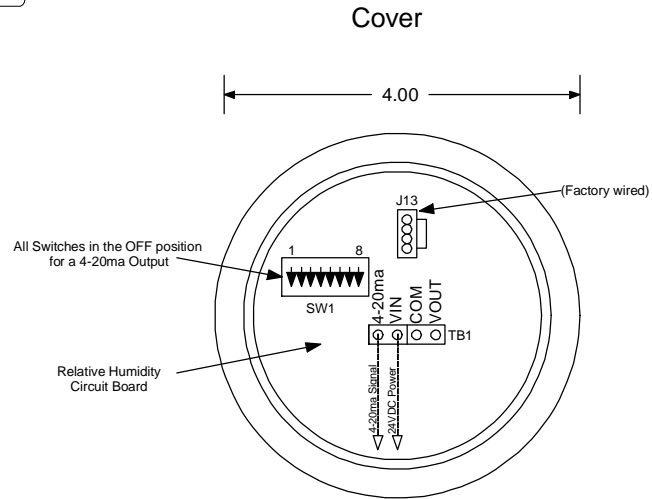

NOTES:

- 1) Requires 2 conductor #24 AWG shielded cable up to 2000' in length. Two Belden #9501 cables may be used. Ground shield at control panel end only. Insulate shield at sensor end.
- 2) Mount with probe pointing down.
- 3) Warning: Sensor must be protected from ingress of moisture. The conduit entering the sensor must be sealed internally with foam or putty to completely prevent air movement. Additionally, drill a weep hole at lowest installed point of the enclosure if it exposed to continuous moisture. Moisture damage is not cover by warranty.

LEGEND

- = Field Wiring
- = Sensor Terminal

Output Selection Switch Settings (SW1)

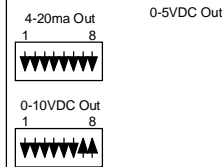

Test Switch Settings (SW1)

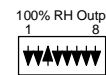
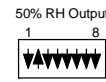
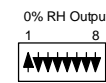

© Copyright 2019 Logix® All Rights Reserved.

CONFIDENTIAL: The information herein is confidential and may NOT be reproduced or divulged without the written permission of The Controls Group, Inc. LOGIX is a registered trademark of The Controls Group, Inc.

Title ACI Humidity Sensor Wiring & Installation Detail		
Date 09/10/12	Rev 01	Drawn by STG
Drawing Filename ACIHumidity-Round.axd		